

DAILY INSPECTION

LPN-YKS

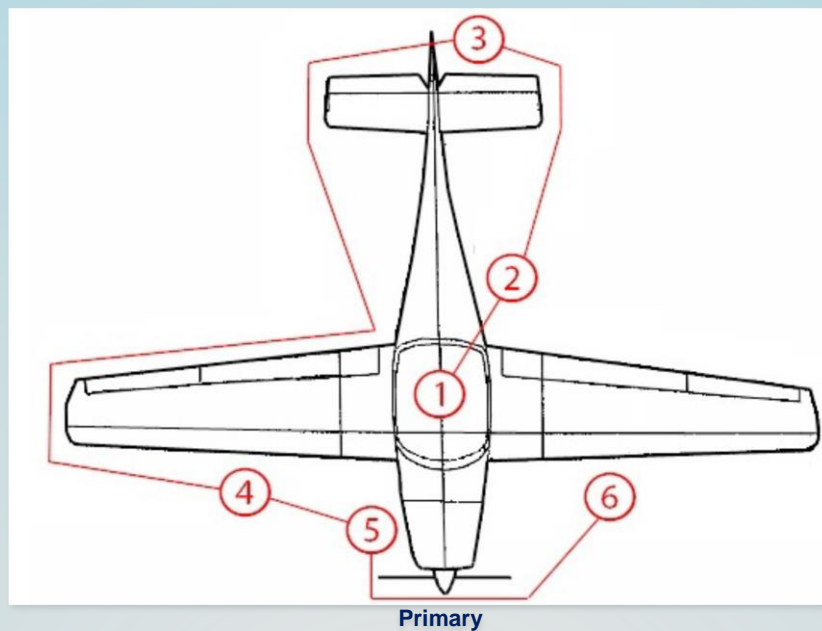

PRIMARY INSPECTION

1. Log-Book, Permit To Fly, Insurance, & Radio Doc.	CHECK
2. Aircraft Visual Check: Level & Tire Air Pressure	CHECK
Fuel Tank Drainage, No Water	CHECK
Fuel Quantity Physical Check	CHECK

1. FLIGHT DECK AREA

1. Magnetos OFF	Starter Key Out	CHECK
2. Master Switch (Up)		ON
3. Fuel Selector		LEFT
4. Seat Belts & Protection Net		CHECK
5. Control Stick (Freedom of Movement)		CHECK
6. Flaps Movement And Up		CHECK
7. Fuel Quantity Instrument		CHECK
8. Nav Lights		ON
9. Landing Lights		ON
10. Visual Check Nav- & Landing Lights		CHECK
11. Nav-, Landing Lights & Master Switch		OFF

2. AIRCRAFT BODY AREA

1. Canopy Free Of Damage	CHECK
2. Static Port Free	CHECK
3. Surface And Body Free Of Damage	CHECK
4. Transponder Antenna	CHECK

3. TAIL AREA

1. Surface Free Of Damage	CHECK
2. Pitch Rudder Attachment point And No Side Movement or Abnormal Sound	CHECK
3. Yaw Rudder Attachment point And No Vertical Move or Abnormal Sound	CHECK
4. Tail Skid	CEHCK

DAILY INSPECTION

LN-YKS

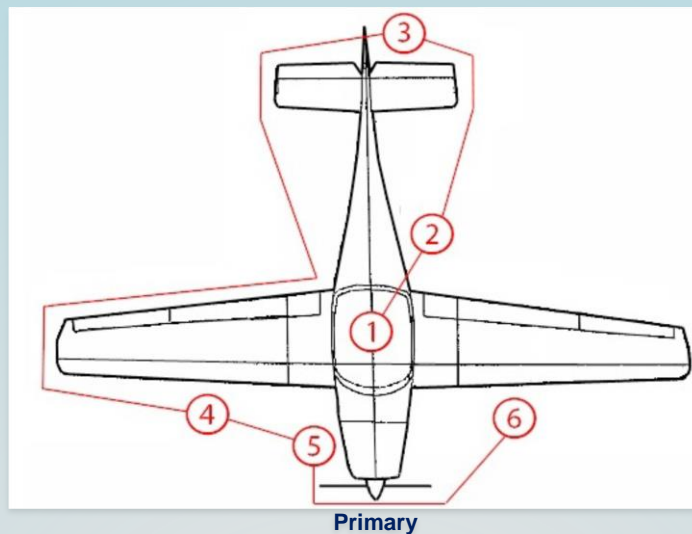

4. RIGHT WING AREA

1. Static Port Free	CHECK
2. Wing Surface Free Of Damage	CHECK
3. Flaps Attached, Secure & Free Of Damage	CHECK
4. Right Landing Gear	CHECK
5. Role Rudder Attachment point And No Movement and No Abnormal Sound	CHECK
6. Wing Attached & No Movement	CHECK
7. Wing Leading Edge Clean & Without damage	CHECK
8. Pitot Probe Remove and Clean	CHECK
9. Parking Bolt Removed	CHECK

5. ENGINE AREA

1. Safety pin Wing Rigging Connection LEFT	CHECK
2. Engine Cowlings Free Of Damage & Clean	CHECK
3. Integrity of Wires, Plugs, Fuel Filters & Couplings	CHECK
4. No Visual damage on Engine Surface	CHECK
5. Coolant Level	CHECK
6. Oil Level	CHECK
7. Propeller Without Damage & Equal Stiffness	CHECK
8. Propeller/Engine Attached & No Movement	CHECK
9. Exhaust system attached	CHECK
10. Nose Wheel	CHECK
11. Safety pin Wing rigging Connection RIGHT	CHECK

6. LEFT WING AREA

1. Wing Surface Free Of Damage	CHECK
2. Leading Edge Clean & Without damage	CHECK
3. Left Landing Gear	CHECK
4. Parking Bolt Removed	CHECK
5. Wing Attached & No Movement	CHECK
6. Role Rudder Attachment Points And No Movement and No Abnormal Sound	CHECK
7. Flaps Attachment, Secure pin & Free Of Damage	CHECK